

TARA

GROUP 10

FIXED
ชุดช่องแสง

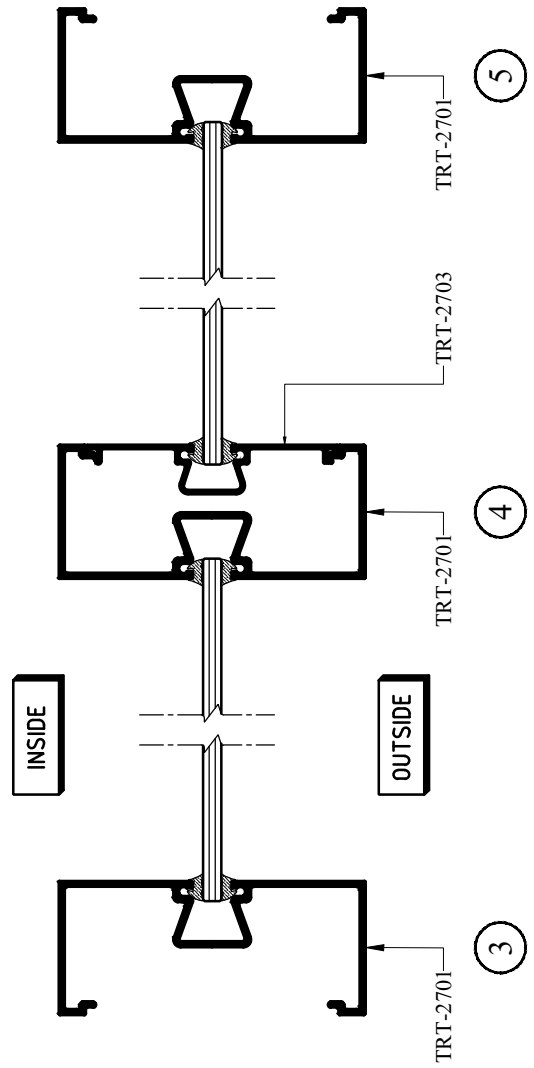
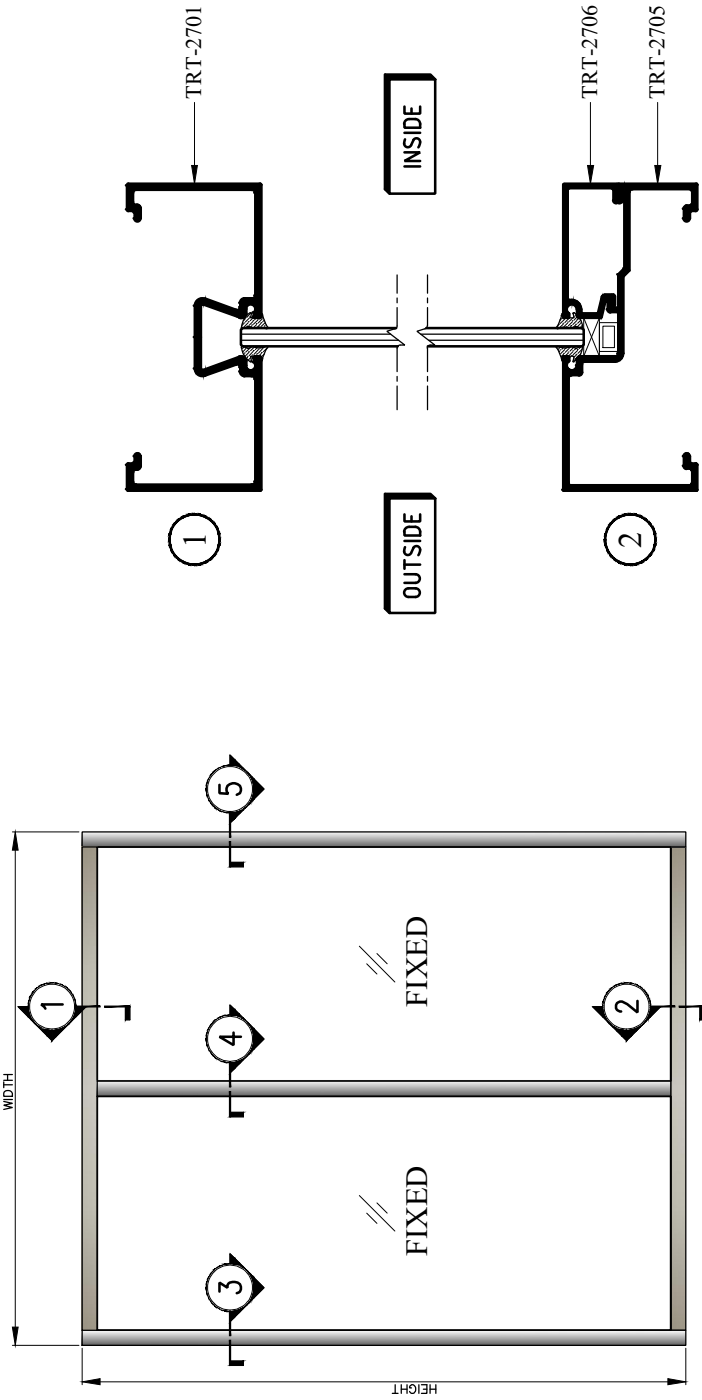

FIXED

ชุดช่องแสง

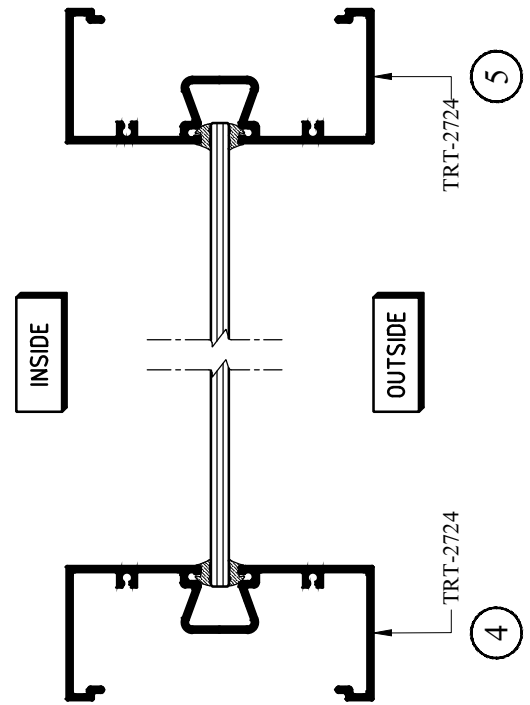
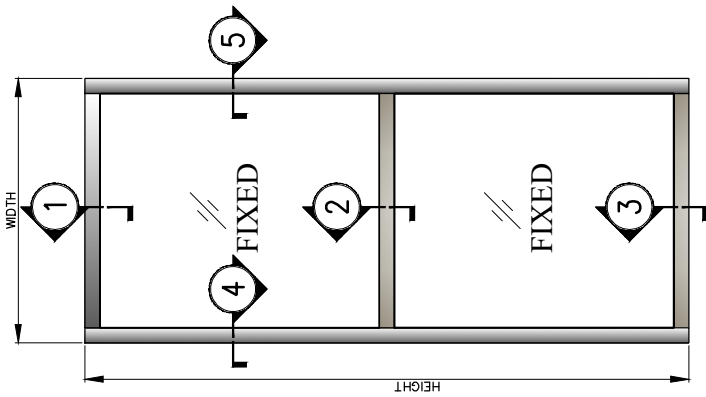
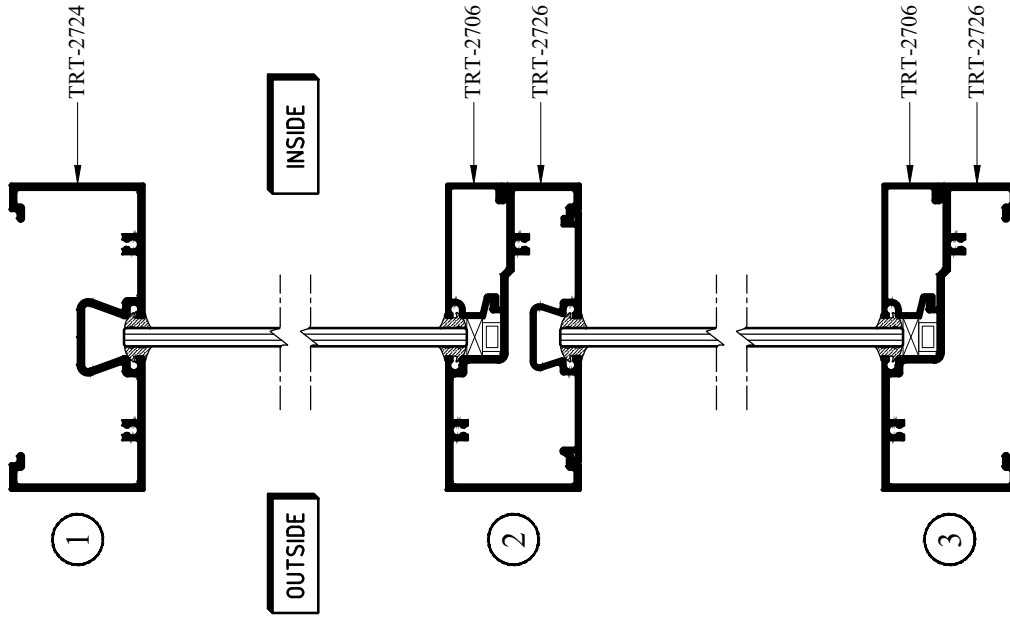

TARA

GROUP 10

FIXED
ชุดช่องแสง

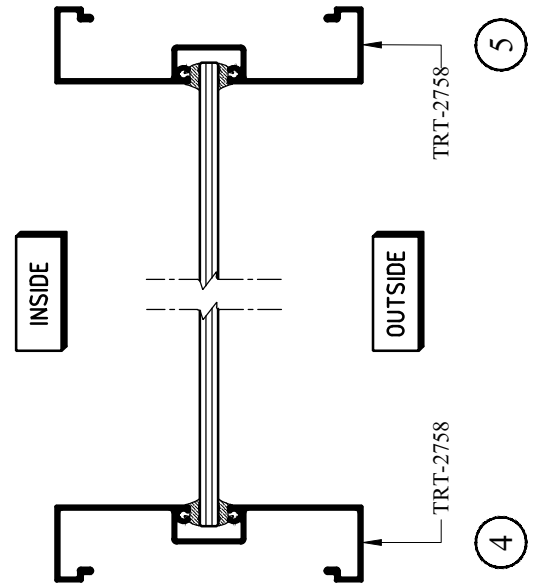
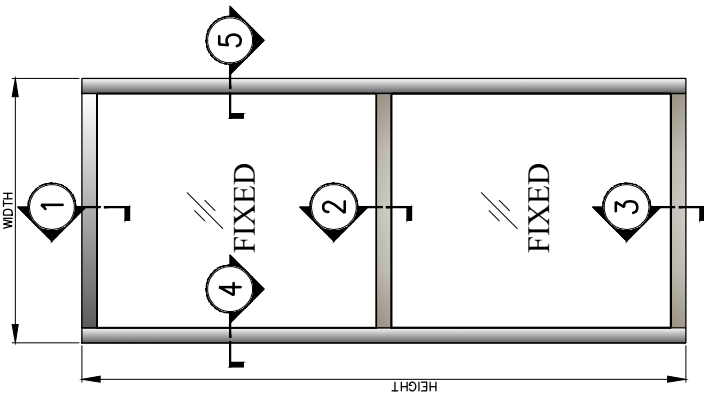
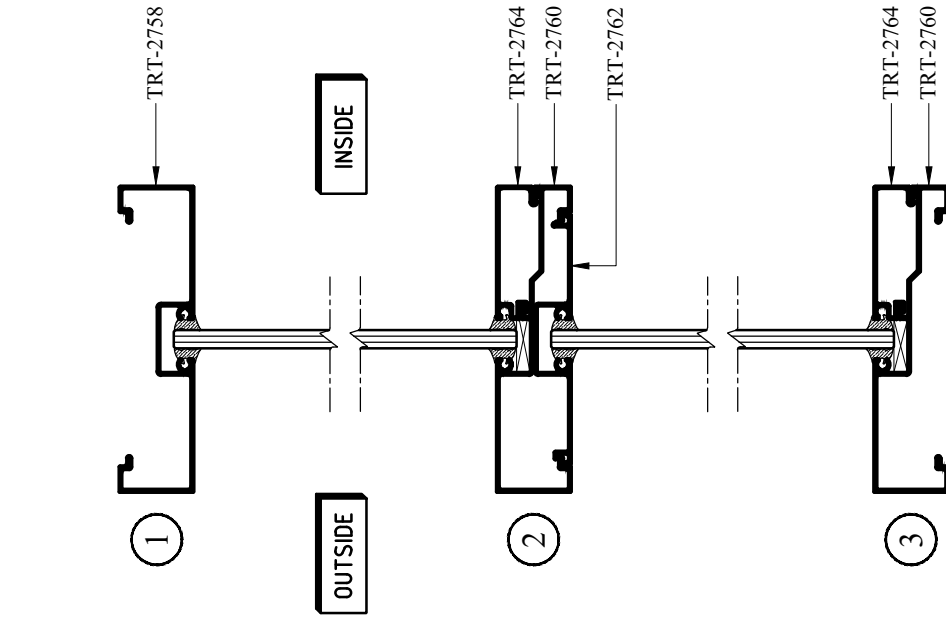

FIXED

ชุดช่องแสง

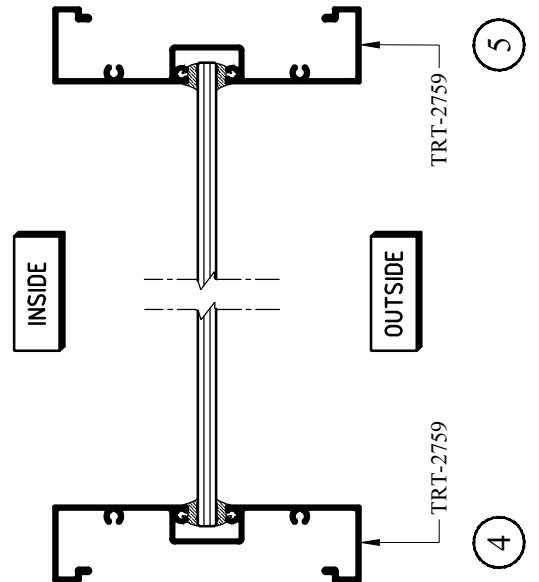
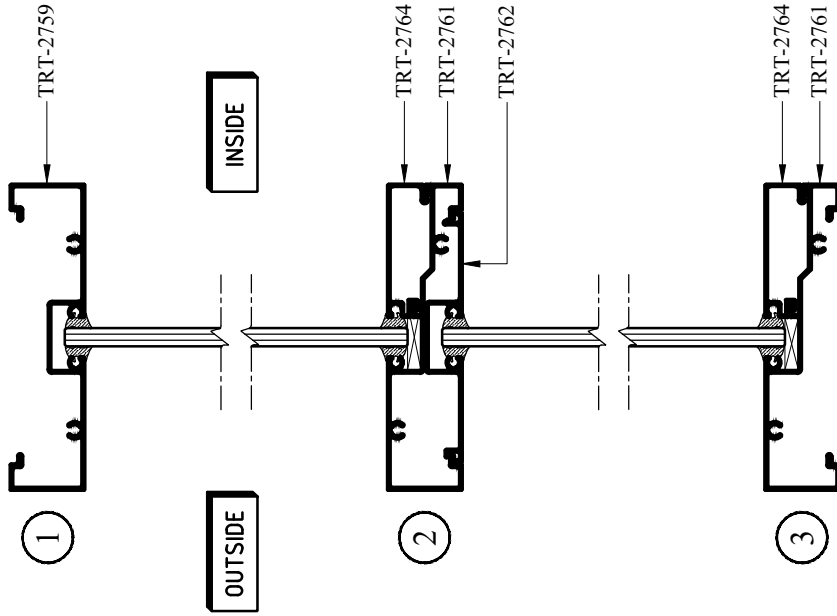
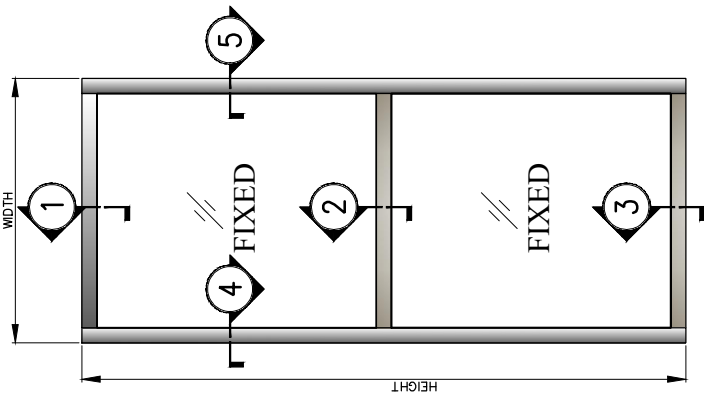

TARA

GROUP 10

FIXED
ชุดช่องแสง

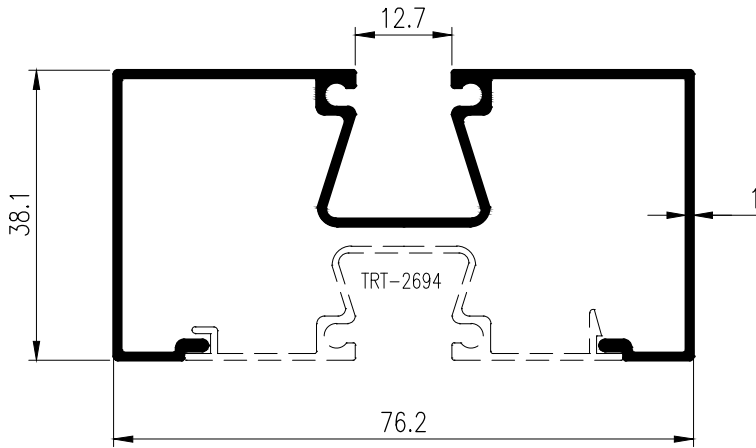

TRT-2689
WT : 0.656 kg./m.

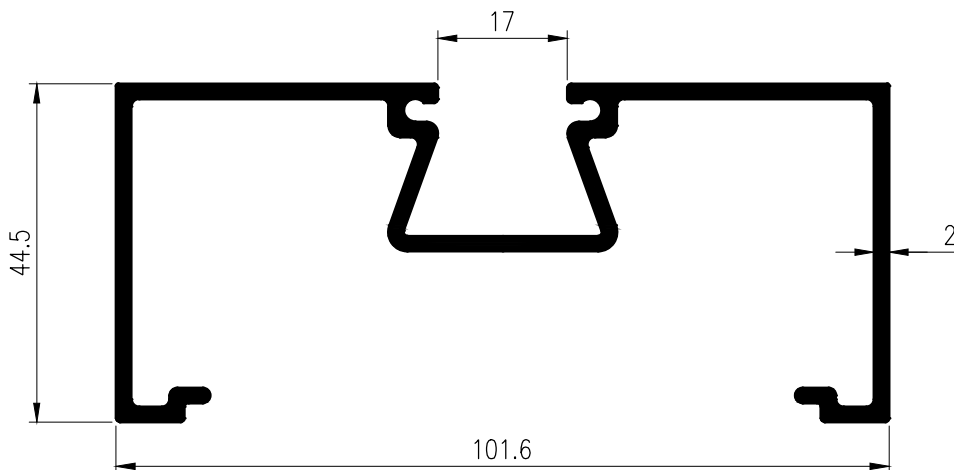

TRT-2712
WT : 1.476 kg./m.

FIXED

ชุดช่องแสง

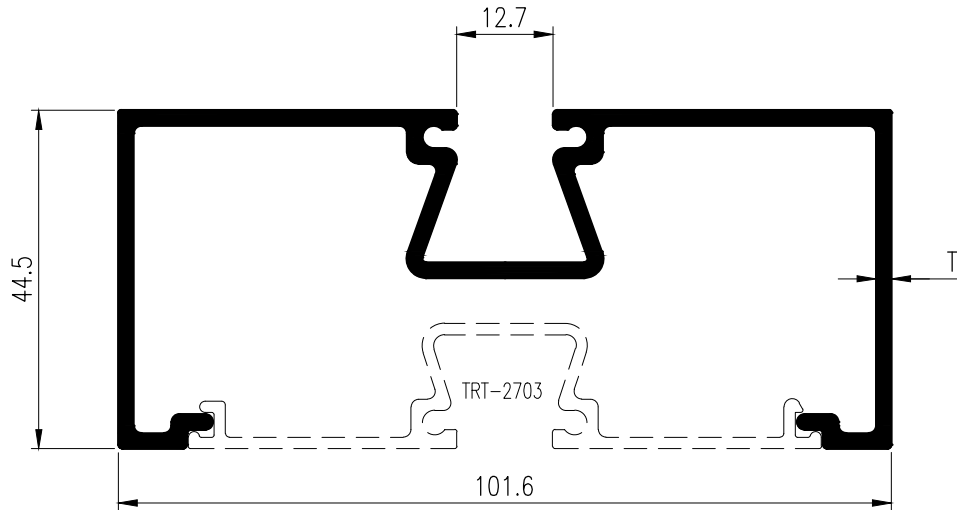

SECTION	THICKNESS (mm.)	WEIGHT (kg./m.)
TRT-0802701	0.80	0.666
TRT-0902701	0.90	0.742
TRT-1002701	1.00	0.805
TRT-1102701	1.10	0.879
TRT-1202701	1.20	0.942
TRT-1502701	1.50	1.130
TRT-1752701	1.75	1.304
TRT-2002701	2.00	1.476

TARA

GROUP 10

FIXED
ชุดช่องแสง

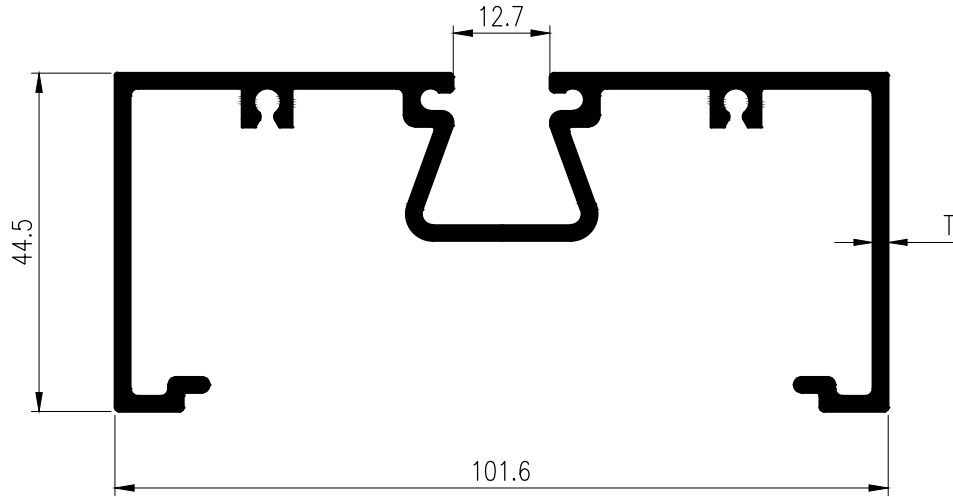

SECTION	THICKNESS (mm.)	WEIGHT (kg./m.)
TRT-1202724	1.20	1.017
TRT-1502724	1.50	1.248
TRT-1752724	1.75	1.409
TRT-2002724	2.00	1.572

FIXED

ชุดช่องแสง

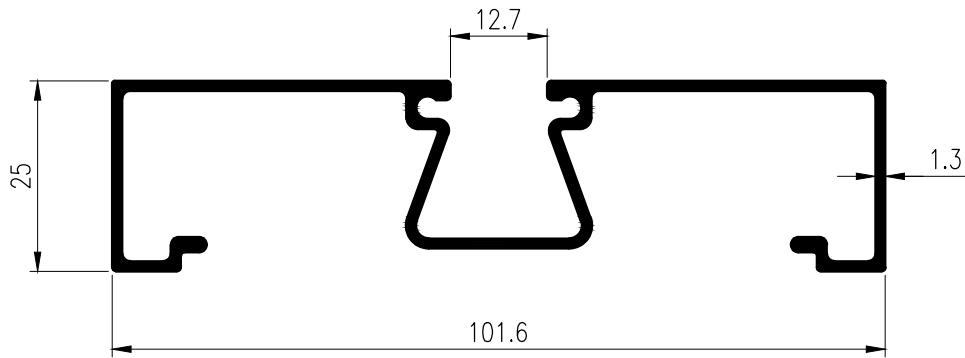

TRT-2739
WT : 0.869 kg./m.

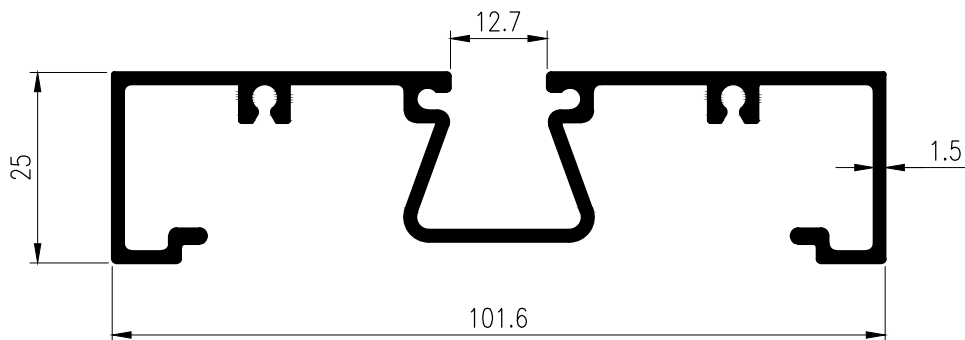

TRT-2743
WT : 1.090 kg./m.

FIXED
ชุดช่องแสง

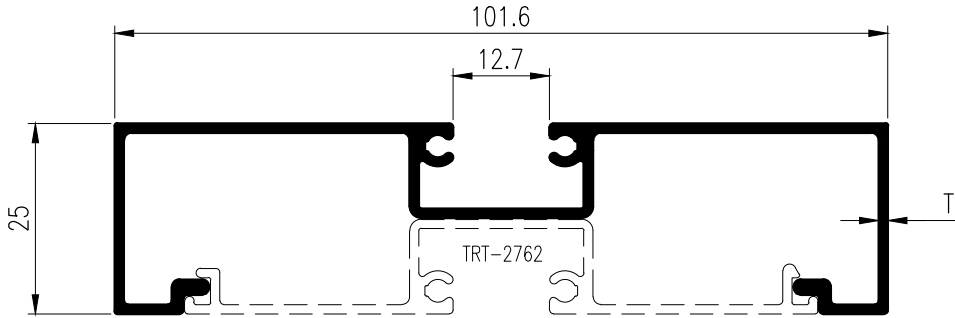

SECTION	THICKNESS (mm.)	WEIGHT (kg./m.)
TRT-1202758	1.2	0.751
TRT-1502758	1.5	0.884
TRT-2002758	2.0	1.056

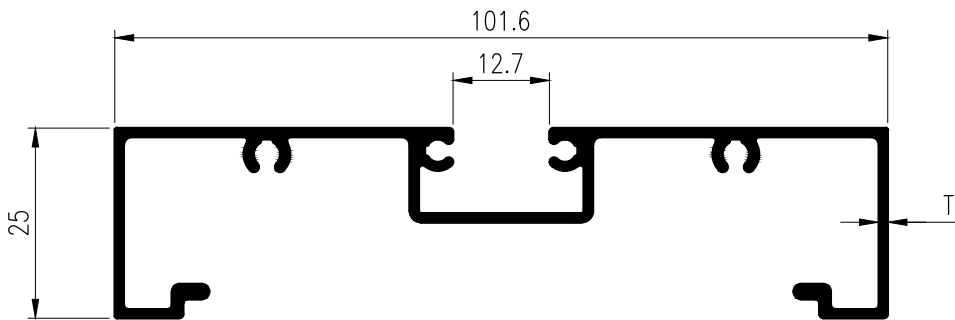

SECTION	THICKNESS (mm.)	WEIGHT (kg./m.)
TRT-1202759	1.2	0.826
TRT-1502759	1.5	0.959
TRT-2002759	2.0	1.130

FIXED

ชุดช่องแสง

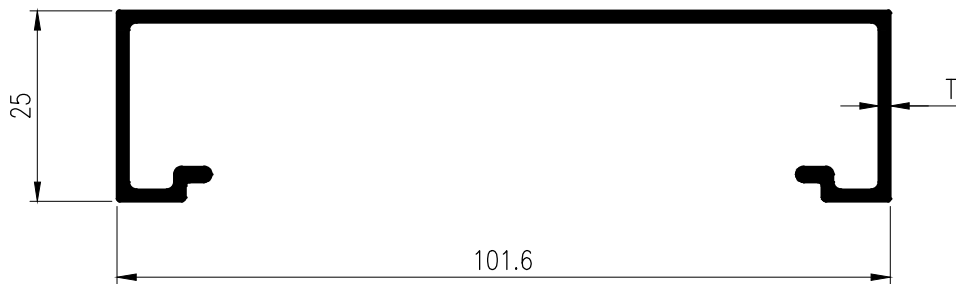

SECTION	THICKNESS (mm.)	WEIGHT (kg./m.)
TRT-1302740	1.3	0.638
TRT-1502740	1.5	0.726

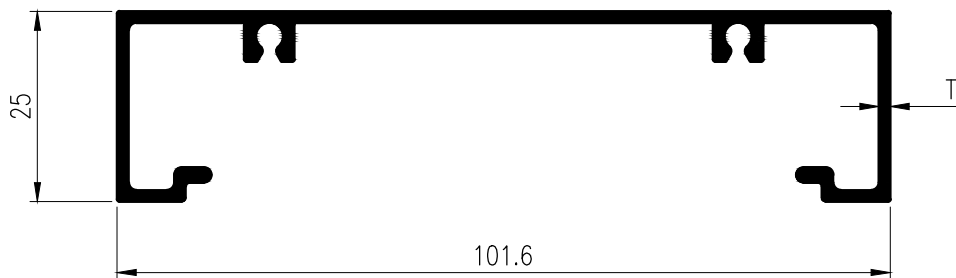

SECTION	THICKNESS (mm.)	WEIGHT (kg./m.)
TRT-1502744	1.5	0.833
TRT-2002744	2.0	1.075

FIXED
ชุดช่องแสง

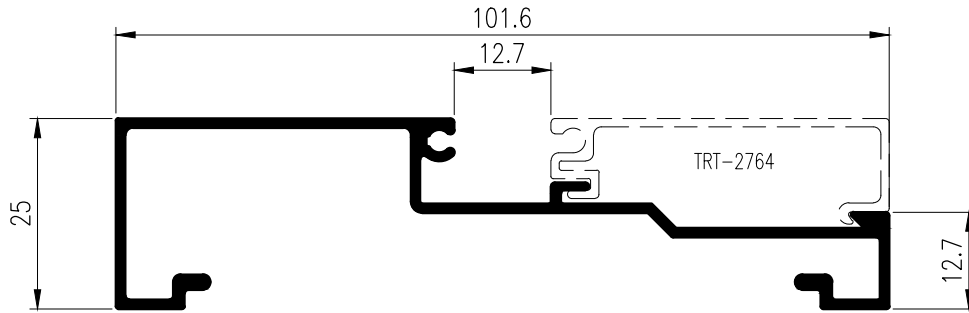

SECTION	THICKNESS (mm.)	WEIGHT (kg./m.)
TRT-1202760	1.2	0.676
TRT-1502760	1.5	0.750
TRT-2002760	2.0	0.855

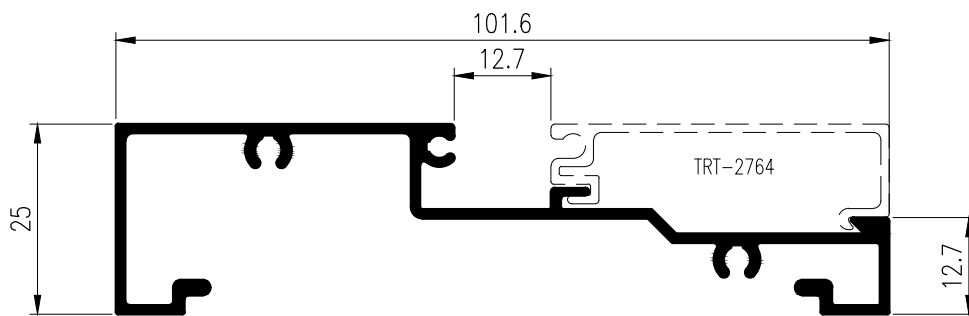

SECTION	THICKNESS (mm.)	WEIGHT (kg./m.)
TRT-1202761	1.2	0.750
TRT-1502761	1.5	0.824
TRT-2002761	2.0	0.929

FIXED

ชุดช่องแสง

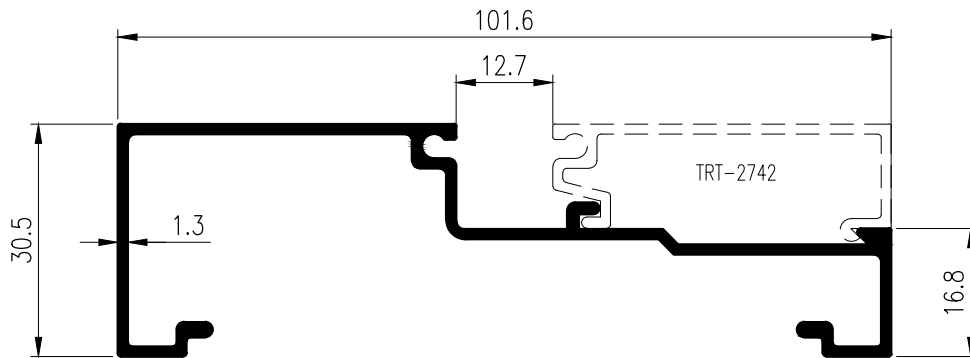

TRT-1302741
WT : 0.737 kg./m.

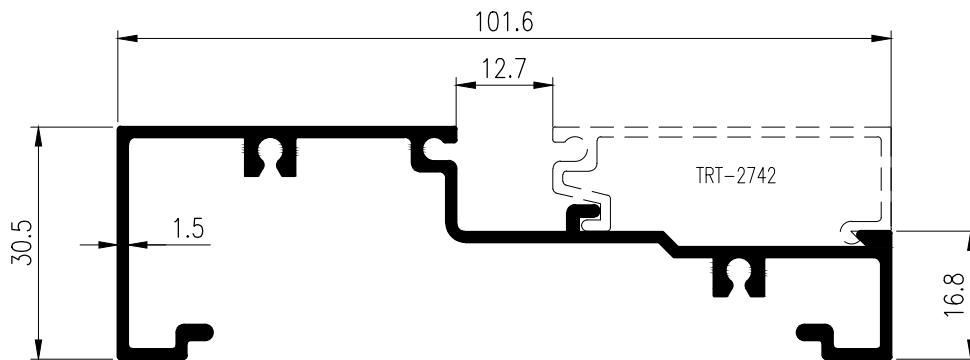

TRT-1502741
WT : 0.937 kg./m.

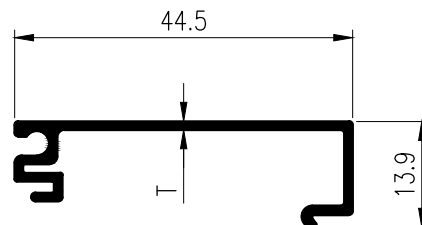

SECTION	THICKNESS (mm.)	WEIGHT (kg./m.)
TRT-1102764	1.1	0.263
TRT-1502764	1.5	0.314

FIXED
ชุดช่องแสง

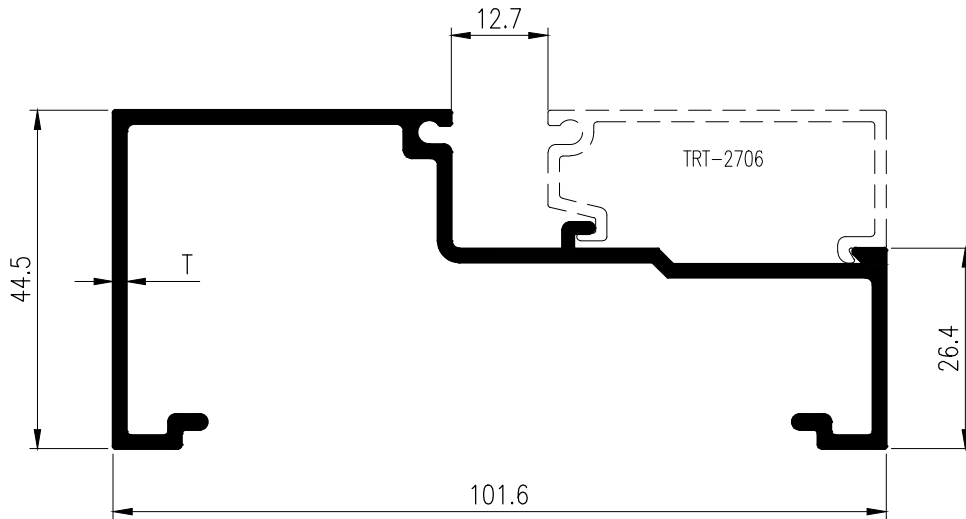

SECTION	THICKNESS (mm.)	WEIGHT (kg./m.)
TRT-0802705	0.80	0.548
TRT-0952705	0.95	0.630
TRT-1052705	1.00	0.654
TRT-1202705	1.20	0.766
TRT-1502705	1.50	0.933
TRT-1752705	1.75	1.076

FIXED

ชุดช่องแสง

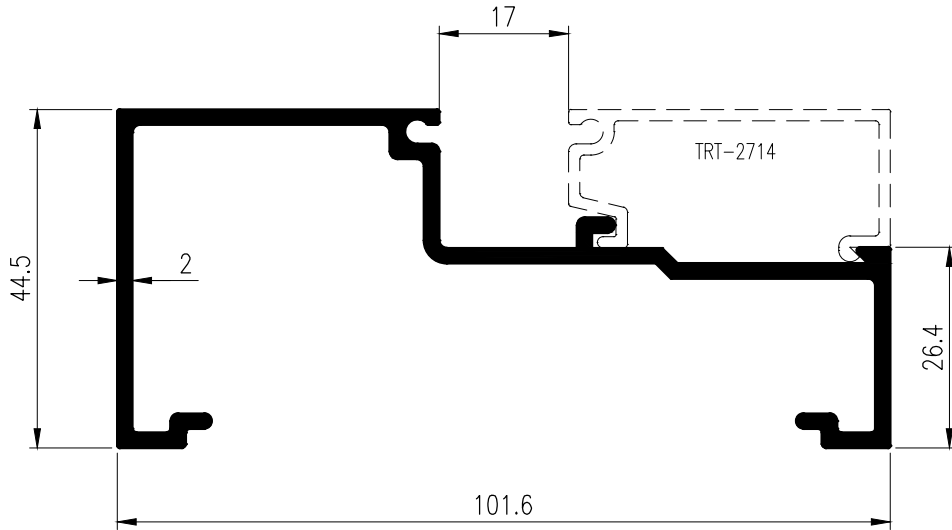

TRT-2713
WT : 1.219 kg./m.

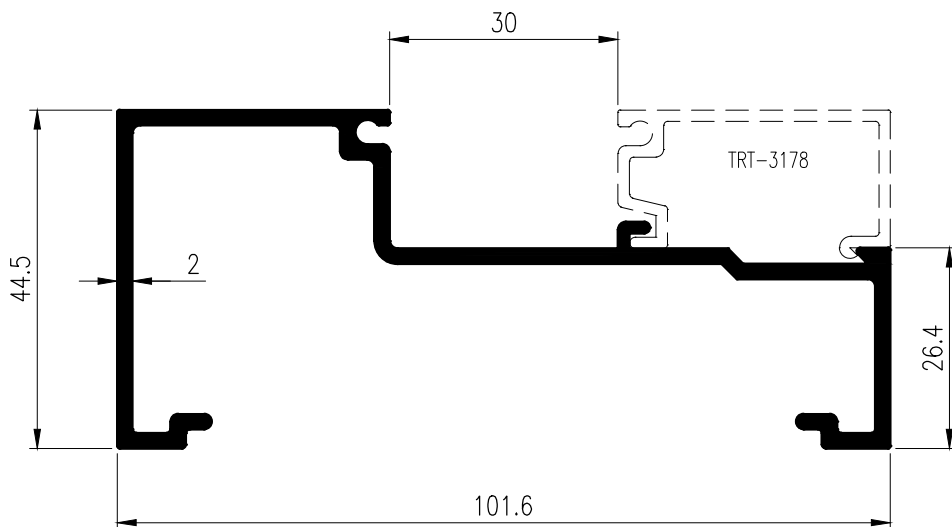

TRT-3177
WT : 1.206 kg./m.

FIXED
ชุดช่องแสง

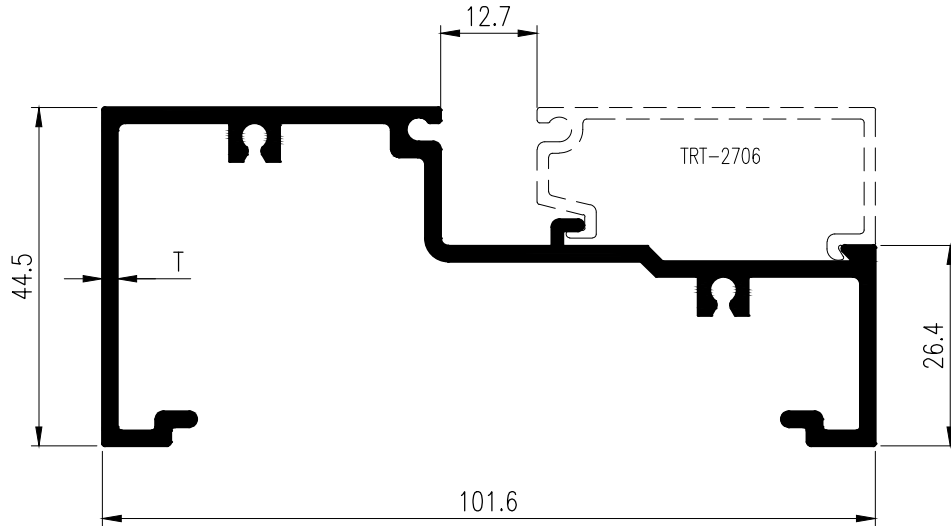

SECTION	THICKNESS (mm.)	WEIGHT (kg./m.)
TRT-1502726	1.50	1.051
TRT-1752726	1.75	1.181
TRT-2002726	2.00	1.314

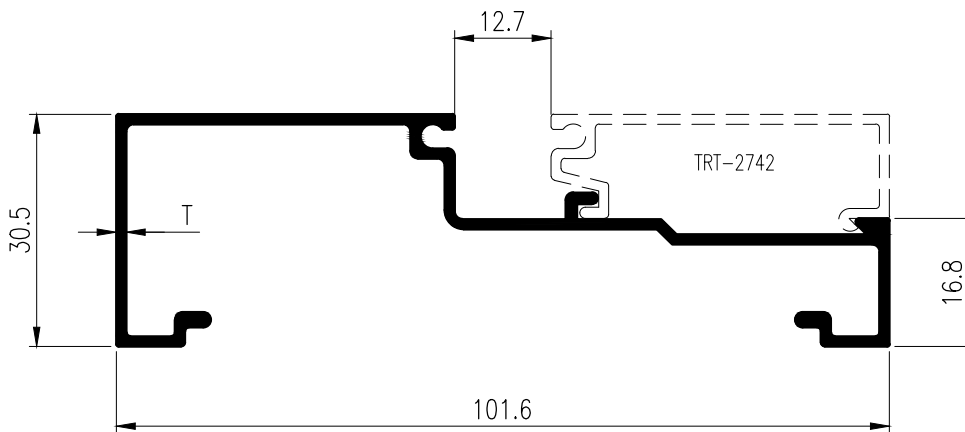

SECTION	THICKNESS (mm.)	WEIGHT (kg./m.)
TRT-1302741	1.3	0.737
TRT-1502741	1.5	0.937

FIXED

ชุดช่องแสง

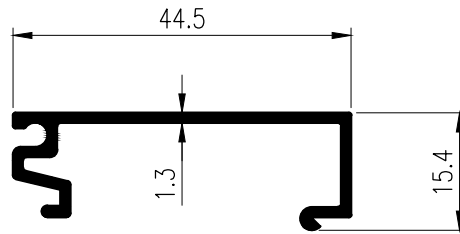

TRT-2742
WT : 0.318 kg./m.

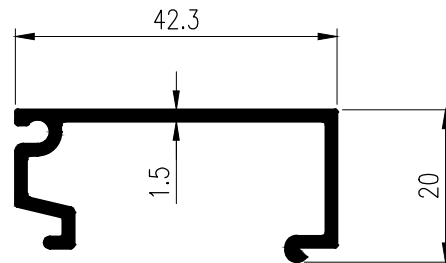

TRT-2714
WT : 0.384 kg./m.

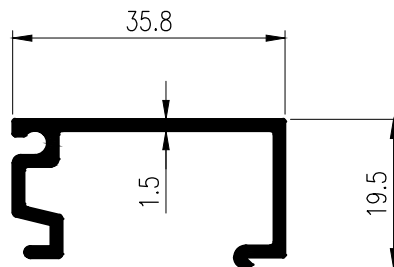

TRT-3178
WT : 0.361 kg./m.

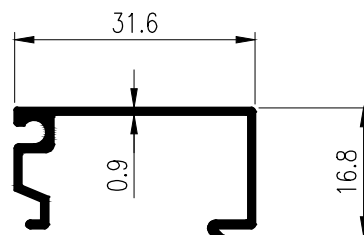

TRT-2695
WT : 0.203 kg./m.

TARA

GROUP 10

FIXED
ชุดช่องแสง

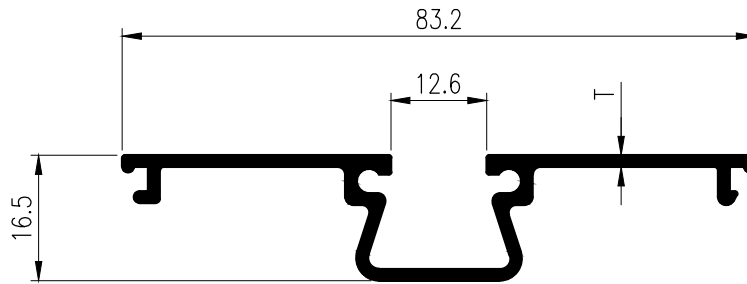

SECTION	THICKNESS (mm.)	WEIGHT (kg./m.)
TRT-0802703	0.8	0.353
TRT-0902703	0.9	0.381
TRT-1002703	1.0	0.419
TRT-1202703	1.2	0.486
TRT-1502703	1.5	0.586

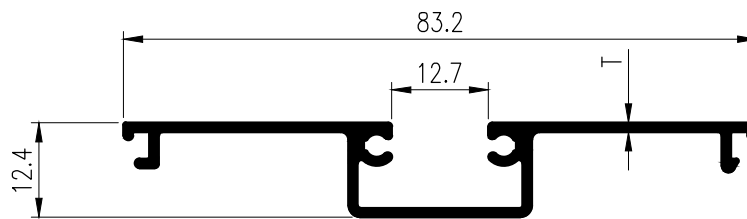

SECTION	THICKNESS (mm.)	WEIGHT (kg./m.)
TRT-1202762	1.2	0.472
TRT-1502762	1.5	0.552
TRT-2002762	2.0	0.613

FIXED

ชุดช่องแสง

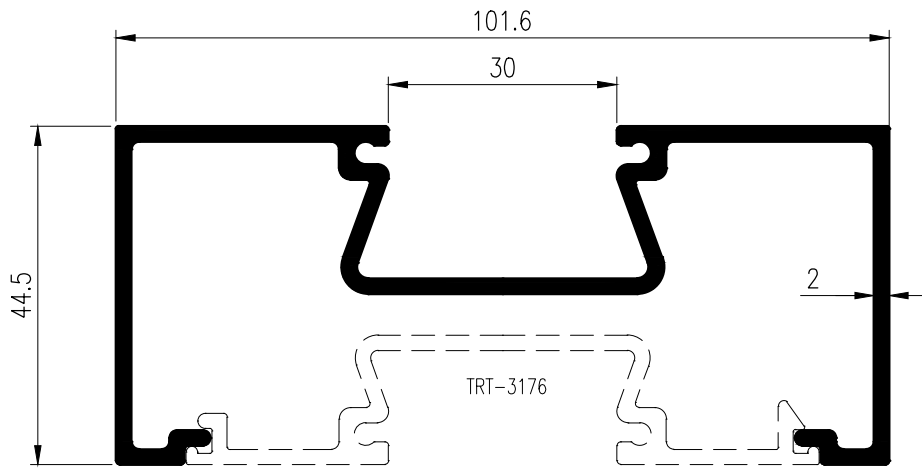

TRT-3175
WT : 1.464 kg./m.

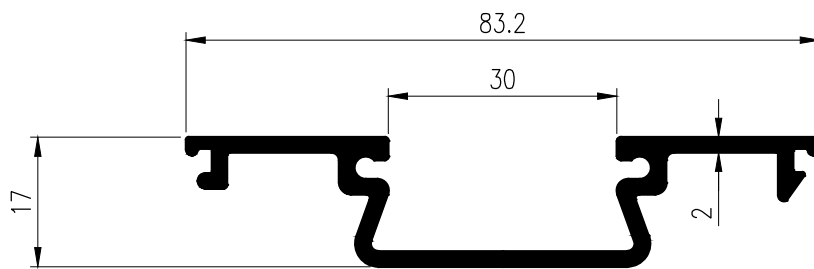

TRT-3176
WT : 0.772 kg./m.

TARA

GROUP 10

FIXED
ชุดช่องแสง

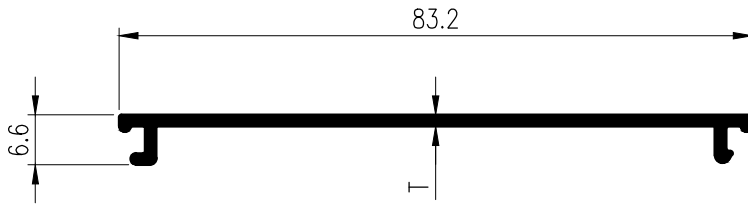

SECTION	THICKNESS (mm.)	WEIGHT (kg./m.)
TRT-0702704	0.7	0.190
TRT-0802704	0.8	0.220
TRT-1202704	1.2	0.318
TRT-1302704	1.3	0.350
TRT-1502704	1.5	0.391

FIXED

ชุดช่องแสง

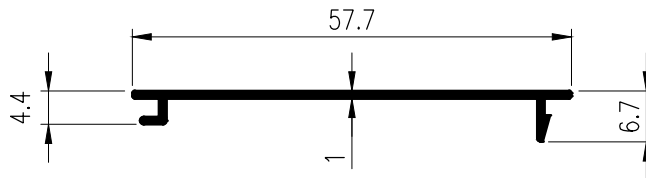

TRT-2693
WT : 0.189 kg./m.

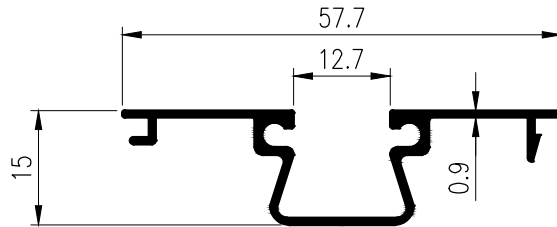

TRT-2694
WT : 0.298 kg./m.

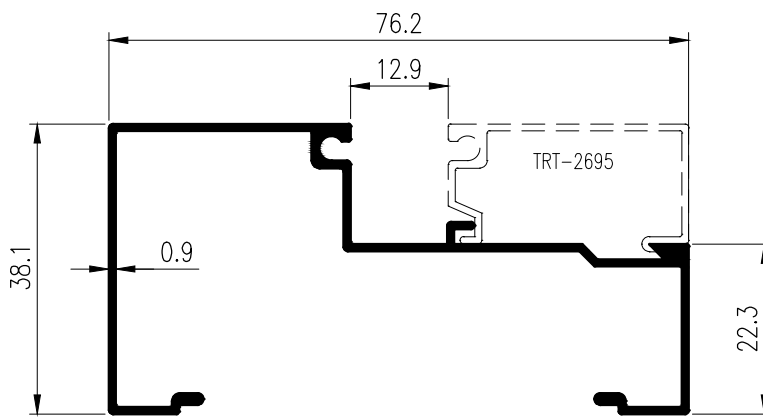

TRT-2697
WT : 0.498 kg./m.

TARA

GROUP 10

FIXED
ชุดช่องแสง

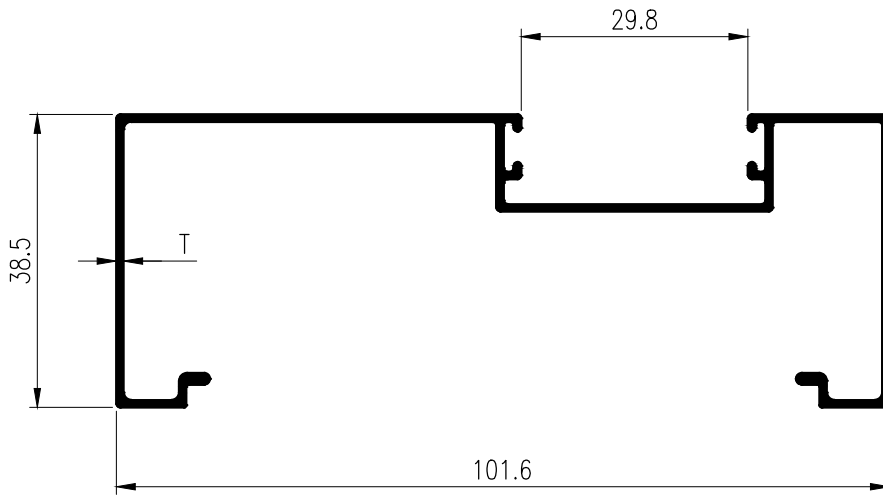

SECTION	THICKNESS (mm.)	WEIGHT (kg./m.)
TRT-0752708	0.75	0.509
TRT-0952708	0.95	0.639

FIXED

ชุดช่องแสง

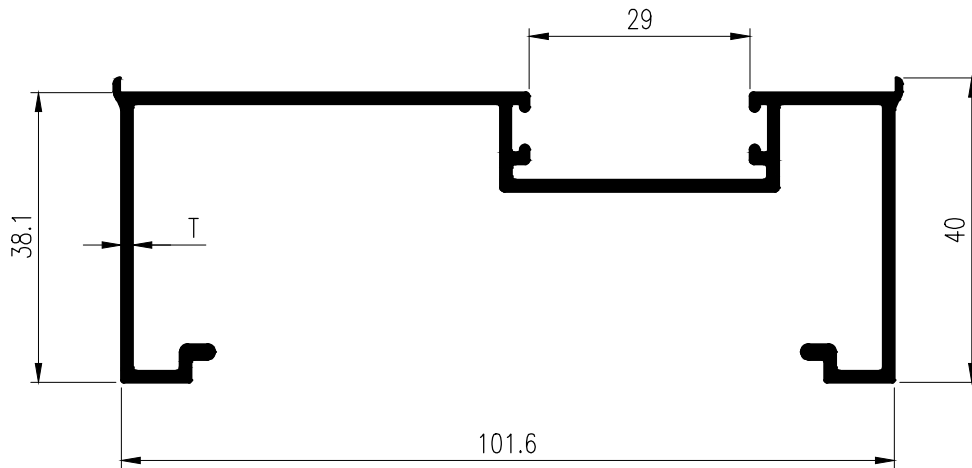

SECTION	THICKNESS (mm.)	WEIGHT (kg./m.)
TRT-0802710	0.8	0.561
TRT-1002710	1.0	0.669
TRT-1502710	1.5	0.985